

## Featured Product: Model 101

### Proven Performance. PRIME Prices.

When you buy a RETRACTA-BELT® you're getting a high quality stanchion from a trusted manufacturer with 50 years of experience. So why buy anything else? RETRACTA-BELT® PRIME stanchions are economically priced, and feature technology and materials that will outperform any other low-cost stanchion on the market. We've analyzed design flaws of other similar products and corrected them to deliver you a low-cost stanchion worthy of the RETRACTA-BELT® name.

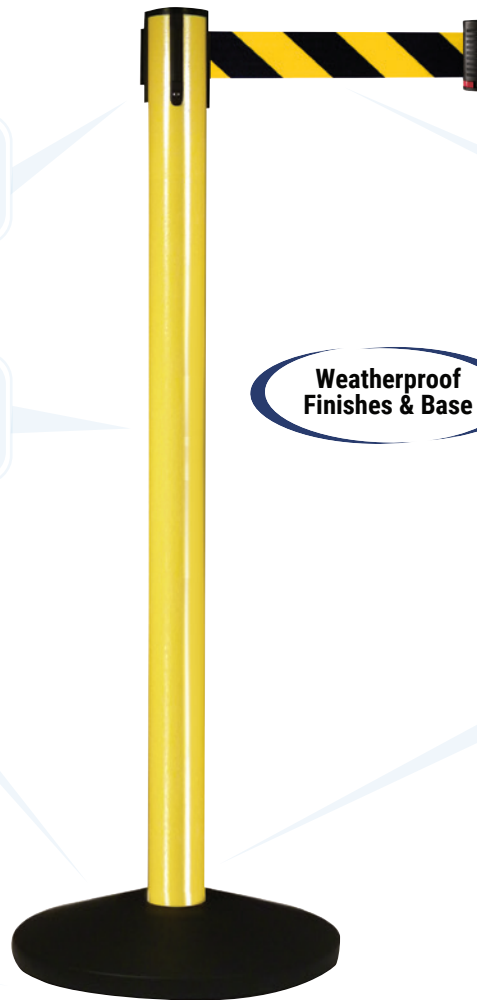

**Strong and slow brake:** made with E-Z Back® PRIME Technology for guaranteed safety.

**Weatherproof post material:** PVC or aluminum post resists the outdoor elements and tough wear and tear.

Standard scuff resistant black ABS base cover.

**Built-in rubber floor protectors:** around the ENTIRE base for maximum protection.

**Weatherproof Finishes & Base**

**Universal belt end:**

- ▶ Works with nearly every stanchion.
- ▶ Locks to prevent accidental release.

**10' belt:** thick, durable and 43% longer than competitors' posts.

**Featuring Exclusive EVERstraight® PRIME Technology**



- ▶ Innovative self-straightening base connection keeps post upright.
- ▶ Heavy base keeps post in place.

**Buyer Beware!** Many low cost stanchions leave out industry standard features such as a slow retracting brake system or a universal belt end that enables connection to existing stanchions. Ensure your product has these critical features.

#### Additional Features

- ▶ Three year warranty.
- ▶ Same day shipping on stock items.
- ▶ Ships Knocked-Down to save you money.
- ▶ Easy assembly, no tools required.

#### Printed Belts



#### Belt End Upgrades



Specs	
Post Material	Aluminum or PVC
Base Cover Material	Scuff Proof Black ABS
Baseweight Material	17 lbs. Cement-Filled with Floor Protectors
Post Diameter	2.5"
Base Diameter	14"
Overall Post Height	40"
Overall Weight	20 lbs.

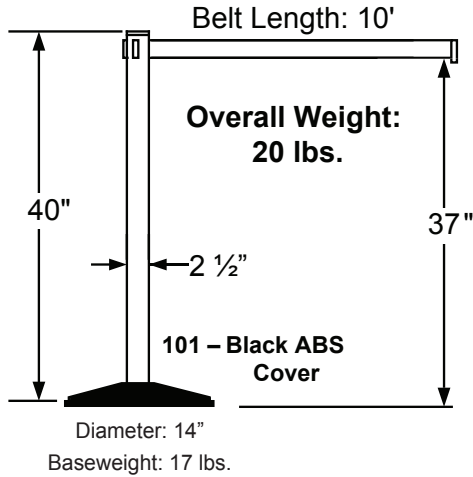

## Stock Finishes

### Aluminum:

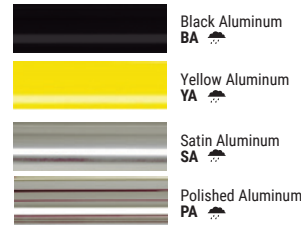

### Plastic:

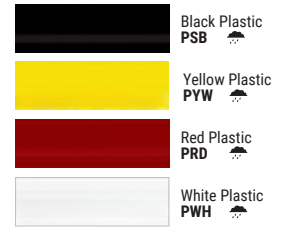

Our aluminum posts are highly weather resistant, and made from aircraft grade material for superior durability and resistance to rusting.

Premium plastic posts are made of 100% virgin premium PVC with additives for superior strength. We use UV inhibitors to ensure color fastness and to prevent the post from drying out and becoming brittle.

Weather Resistant

These post finishes are intended for outdoor use. For a wider range of color options, please see the **RETRACTA-BELT® PRIME** Single Line Post flyer.

## Stock Belt



## Standard Belt Options



## Specialty Belt Options (Double Sided)

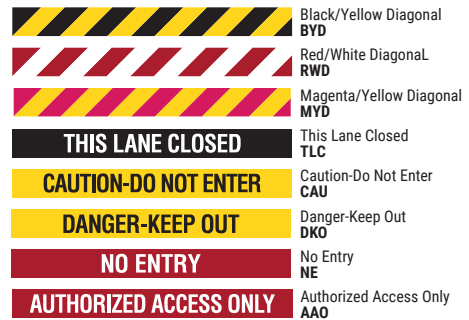

## Custom Dye-Sub Belt Samples

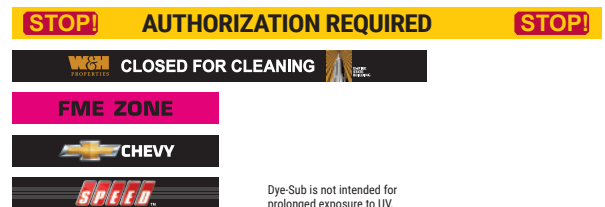

Dye-Sub is not intended for prolonged exposure to UV.



Due to printing limitations, colors shown may not represent actual product colors. Please call for samples if required.