

Featured Product: Model PSBC

All-in-one maintenance cart and barrier system

The Portable Safety Barrier Cart holds up to eight **RETRACTA-BELT**[®] Posts which create up to 120' of safety zone around the work area. These barriers help to warn and protect against hazards during maintenance or repair. The cart provides a safe and easy way to move tools, materials, and other supplies around the facility.

Holds up to 8 **RETRACTA-BELT**[®] Posts

- 10' or 15' belt lengths, multiple belt colors and post finishes available.

See reverse side for specs and options.



Kit shown: Cart + 4 Posts and PLASTIC-FILLABLE Base

Integrated tool holder and shelf: for a portable work station.

Zippered trash container: for easy trash bag removal.

- Two base options:**
- Crush-proof **RECYCLED-RUBBER** Base.
 - Lightweight **PLASTIC-FILLABLE** Base.

Typical Uses

Maintenance: Block escalators, elevators, or moving walkways while work is being performed.

Janitorial and Sanitation: Set up safety barriers for wet floors and other hazards.

Manufacturing: Close aisles or block hazards while machinery is being repaired.



Kit shown: Cart with Additional 4 Posts

Post Options and Specs

Choose your cart configuration in three easy steps:

STEP 1: Choose Belt Length + Base Style

RECYCLED-RUBBER Base			PLASTIC-FILLABLE Base		
	10' Belt	15' Belt		10' Belt	15' Belt
Cart + 4 Posts	✓ MODEL PSBK302	✓ MODEL PSBK322	Cart + 4 Posts	✓ MODEL PSBK303	✓ MODEL PSBK323
Additional 4 Posts	✓ MODEL PSBA303	✓ MODEL PSBA322	Additional 4 Posts	✓ MODEL PSBA303	✓ MODEL PSBA323
Overall Weight of Post + Base	23 lbs.	25 lbs.	Overall Weight of Post + Base	7 lbs. empty 21 lbs. filled w/water 28 lbs. filled w/sand	9 lbs. empty 23 lbs. filled w/water 30 lbs. filled w/sand
Head Color	N/A	Black	Head Color	N/A	Black

- Crush-proof rubber will withstand the harshest environments.



- Weighs only 2 lbs. when empty for low shipping costs.
- Fills with sand or water to increase base weight up to 23 lbs.
- Easy to transport and store.



STEP 2: Choose Post Finish

Post Stock Finishes

Finish	Black Aluminum	Black PVC	Yellow PVC	Red PVC	White PVC
Order Code	BA	PSB	PYW	PRD	PWH
Post Material	Alum.	PVC	PVC	PVC	PVC
Weather Resistant	✓	✓	✓	✓	✓

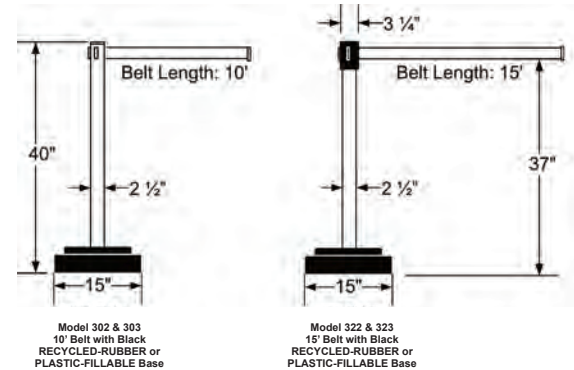

STEP 3: Choose Belt Color

Standard Belt Options	Specialty Belt Options (Double Sided)	Custom Dye-Sub Belt Samples
<ul style="list-style-type: none"> Black BK Green GN Grey GR Dark Green DG White WH Light Blue LB Brown BN Blue BL Maroon MN Dark Blue DB Red RD Purple PL Orange OR Fluorescent Yellow FY Yellow YW Fluorescent Orange FO Black/White Stripe BW 	<ul style="list-style-type: none"> Black/Yellow Diagonal BYD Red/White Diagonal RWD Magenta/Yellow Diagonal MYD THIS Lane Closed TLC Caution-Do Not Enter CAU Danger-Keep Out DKO No Entry NE Authorized Access Only AAO 	<ul style="list-style-type: none"> FME ZONE CHEVY BLUE GUANA SPEED COX <p>Dye-Sub is not intended for prolonged exposure to UV.</p>

To Order, Specify:

Due to printing limitations, colors shown may not represent actual product colors. Please call for samples if required.

PSBK322 PRD — BYD
1: MODEL # 2: FINISH CODE 3: COLOR CODE

Portable Barrier Safety Cart Specs

Material	Black Plastic	Empty Cart Weight	33 lbs
Overall Dimensions	46.0" x 21.8" x 38.4"	Trash Bag Capacity	24 gal.

Cart available for individual sale: MODEL PSB-CART

✓ Ready for outdoor use